

Maximum RPM 4500

ITEM NAME	Ø D	Ø D1	Ø D2	L	L1	L2
MT1 Revolving Center With Bullet.	12.065	15.0	36.0	53.50	60.50	17.0
MT2 Revolving Center With Bullet.	17.78	20.0	45.0	64.0	65.0	24.0
MT3 Revolving Center With Bullet.	23.825	22.0	50.0	81.0	70.50	27.50
MT4 Revolving Center With Bullet.	31.267	32.0	70.0	102.50	102.50	41.0
MT5 Revolving Center With Bullet.	44.399	40.0	90.0	129.50	129.0	50.50

CNC DEAD CENTER WITH DRAW OFF NUT.

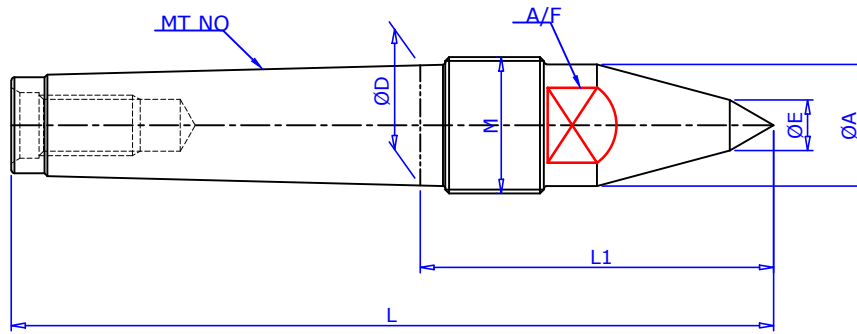

MT NO	Ø D	L	L1	Ø E	Ø A	M	A/F
MT2	17.78	118	54	10	18.0	M22X1.5P	14
MT3	23.825	148	67	10	24.10	M27X1.5P	19
MT4	31.267	186.5	84	14	36.60	M36X1.5P	27
MT5	44.399	242	112	16	44.70	M48X1.5P	36
MT6	63.348	330	148	20	63.80	M68X1.5P	55

FULL MALE CENTER WITH DRAW OFF NUT.

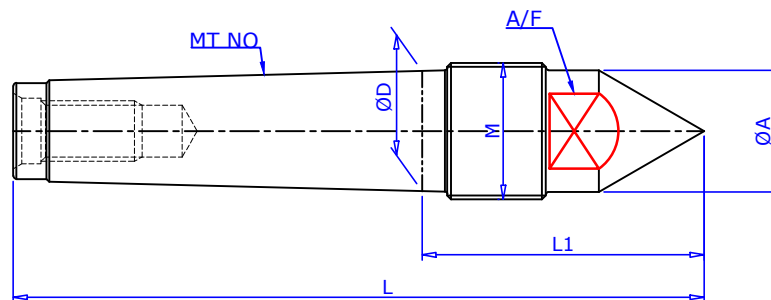

MT NO	Ø D	L	L1	Ø A	M	A/F
MT1	12.065	90	36.5	12.2	M16X1.5P	10
MT2	17.78	112	48.0	18.0	M22X1.5P	14
MT3	23.825	138	57.0	24.1	M27X1.5P	19
MT4	31.267	175	72.5	31.6	M36X1.5P	27
MT5	44.399	217	87.5	44.7	M48X1.5P	36
MT6	63.348	190	108.0	63.8	M68X1.5P	55

DRAW OFF NUT (DIN-807)

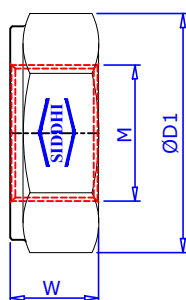

DRAW-OFF NUT(DIN-807)		
W	Ø D1	M
12.0	25.0	M16X1.5P
15.5	32.0	M22X1.5P
17.5	41.0	M27X1.5P
21.0	55.0	M36X1.5P
23.0	75.0	M48X1.5P
25.5	100.0	M68X1.5P